

Sheepylove Blue Fish Build Doc

Updated: 2026-04-05

It's woolly, it's greasy, it's Sheepylove.

Disclaimer: All trademarks and registered trademarks are the property of their respective owners. The company, product, and service names used in this document are for comparative purposes only. Use of these names, logos, and brands does not imply affiliation nor endorsement.

Sounds like Menatone Blue Collar

A nice iteration on the classic OD design. This has a bit more gain, and a presence control to dial in (or out) the highs as you add more gain.

Like all overdrives, it stacks pretty well with others, so try it with an amp-type pedal like the Hot Teacher or Frizzler.

Copyright: Sheepylove.com 2026-04-05

Bill of Materials

Reference	Value	Quantity	Notes
C1	100u	1	
C2	47u	1	
C3	22n	1	
C4	100p	1	
C5-C8	100n	4	
D1	1N5817	1	
D2	LED	1	
D3-D5	1N4148	3	
IC1	TL072	1	
POT1	B250k	1	
POT2	A500k	1	
POT3	B25k	1	
POT4	B5k	1	
R1	CLR	1	
R2	22	1	
R3, R4, R8	10k	3	
R5, R7	1M	2	
R6	33k	1	
R9, R12	470	2	
R10, R13	2k2	2	
R11	20k	1	

Copyright: Sheeppylove.com 2026-04-05

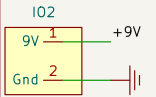
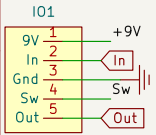
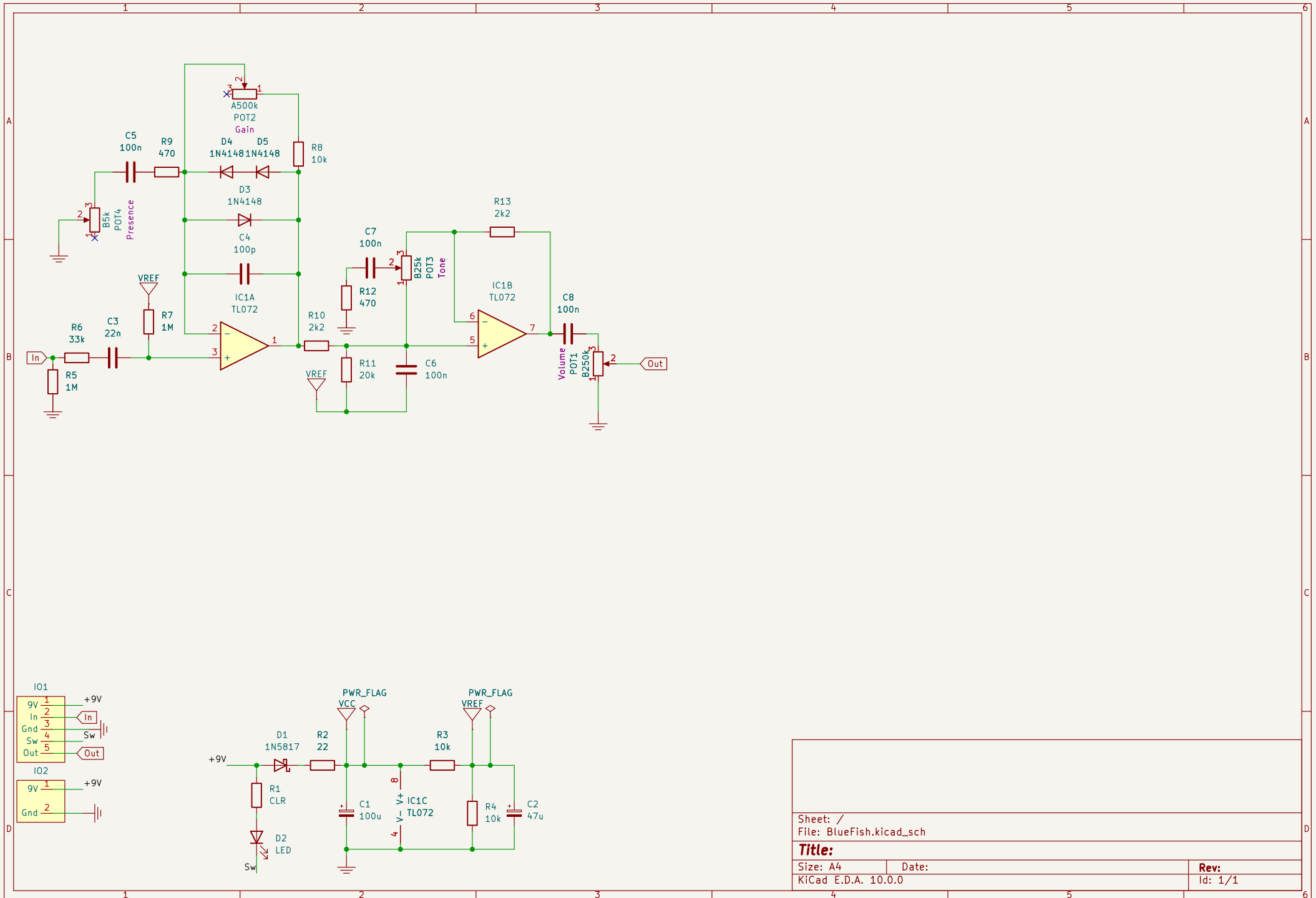

Sheet: /	
File: BlueFish.kicad_sch	
Title:	
Size: A4	Date:
KiCad E.D.A. 10.0.0	Rev: 1/1

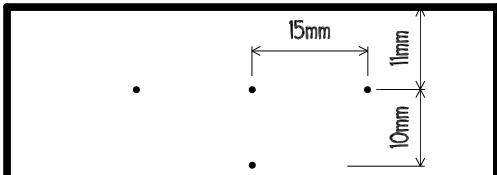

With a sheepy kind of love.

Sheepylove Drill Template

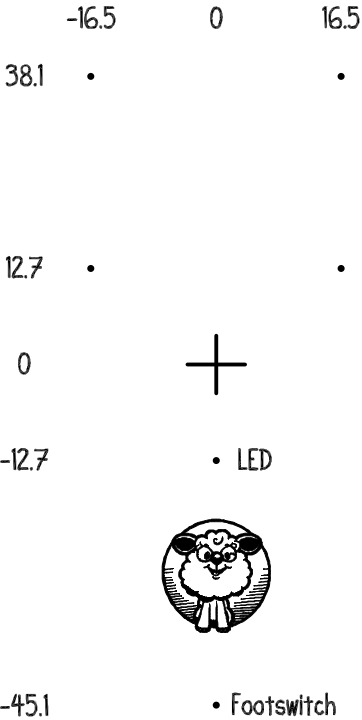

Print 1:1 scale.
All units are in millimeters.