

Sheepylove Butter Lamb Build Doc

Updated: 2026-03-04

It's woolly, it's greasy, it's Sheepylove.

Disclaimer: All trademarks and registered trademarks are the property of their respective owners. The company, product, and service names used in this document are for comparative purposes only. Use of these names, logos, and brands does not imply affiliation nor endorsement.

Sounds like the Vemuram Butter Machine

Copyright: Sheepylove.com 2026-03-04

Bill of Materials

Reference	Value	Quantity	Notes
C1,C2,C11	47u	3	
C3-C5,C19	100n	4	
C6,C18	22p	2	
C7,C8,C13,C20	47n	4	
C9	220p	1	
C10	220n	1	
C12	10n	1	
C14	120n	1	
C15	15n	1	
C16	1u	1	
C17	100p	1	
D1	1N5817	1	
D2	LED	1	
D3,D4	1N4148	2	
IC1,IC2	LF353	2	
POT1,POT2	B100k	2	
POT5	B250k	1	
POT6	B10k	1	
Q1	2N5088	1	
R1	CLR	1	
R2	100	1	
R3,R4,R8,R10,R14,R17,R19,RV1	10k	8	
R5	1M	1	
R6,R21	1k	2	
R7	499k	1	
R9	100k	1	
R11	470	1	
R12,R13	2k2	2	
R15,R18	6k8	2	
R16	1k8	1	
R20	22k	1	

Copyright: Sheepylove.com 2026-03-04

PCB Images

Top View

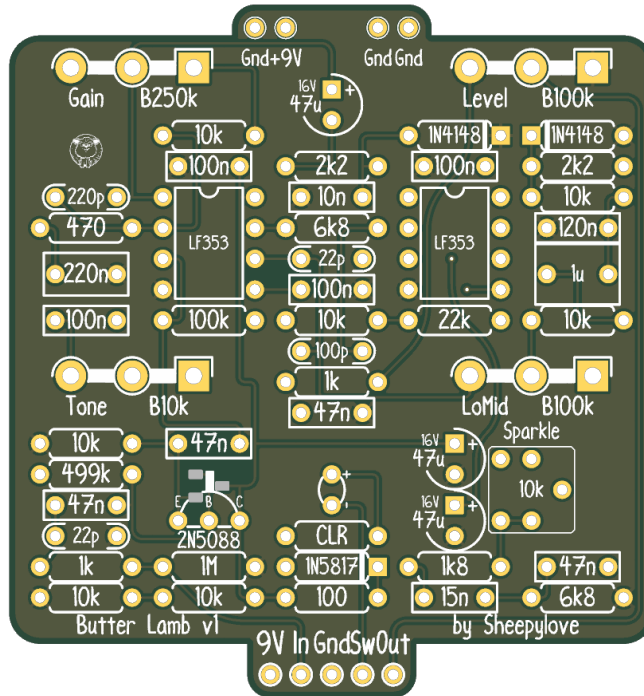

Bottom View

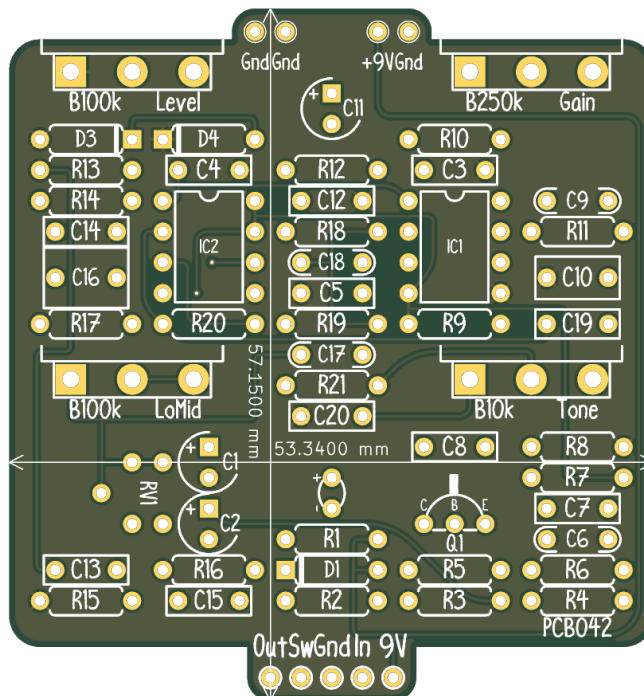

Copyright: Sheepylove.com 2026-03-04

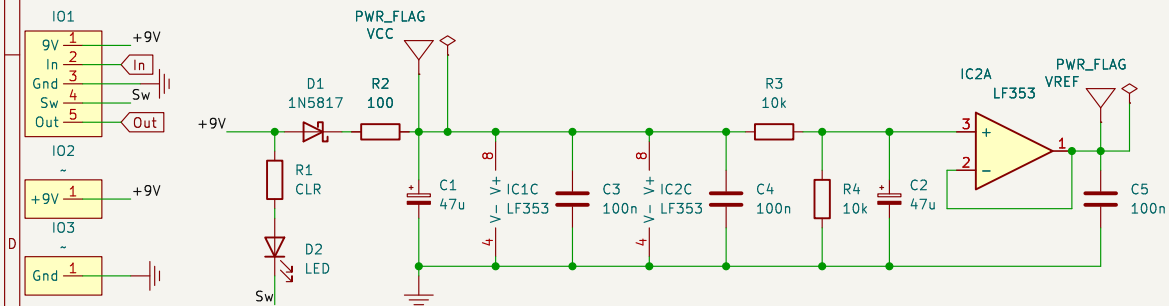
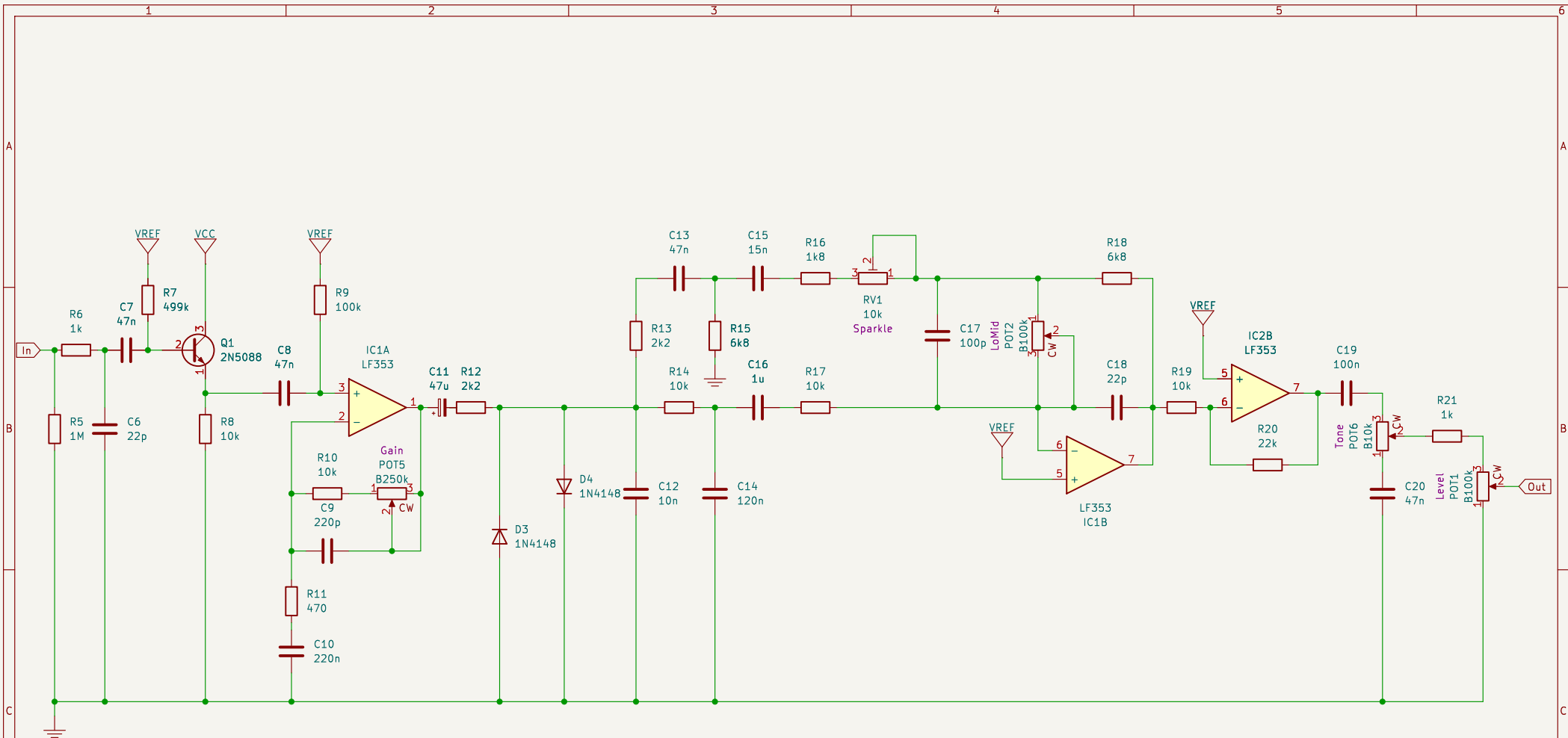

Sheet: /		Date:	
File: ButterLamb_v1.0.kicad_sch			
Title:		Rev:	
Size: A4	KiCad E.D.A. 9.0.7		Id: 1/1

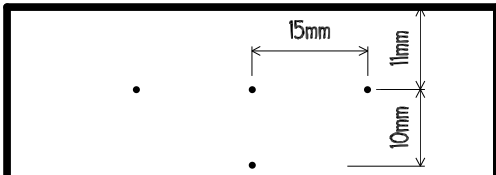

With a sheepy kind of love.

Sheepylove Drill Template

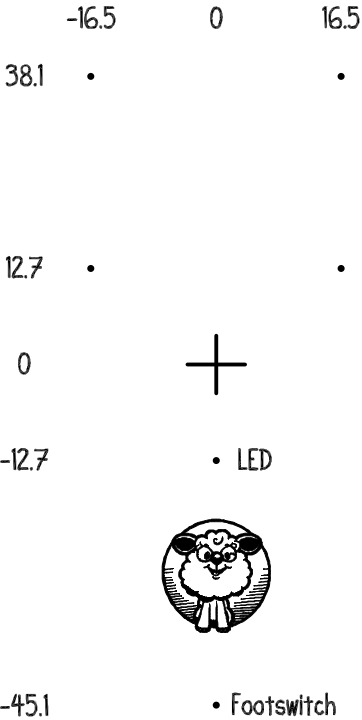

Print 1:1 scale.
All units are in millimeters.