

Sheepylove Hyper Sheep Build Doc

Updated: 2026-03-04

It's woolly, it's greasy, it's Sheepylove.

△ **LEGACY BUILD WARNING:** This is a legacy build. The I/O may be different from the standard and the LED may not be onboard or may not be in the place where you expect.

Disclaimer: All trademarks and registered trademarks are the property of their respective owners. The company, product, and service names used in this document are for comparative purposes only. Use of these names, logos, and brands does not imply affiliation nor endorsement.

Sounds like a Boss HM-3

Copyright: Sheepylove.com 2026-03-04

Bill of Materials

Reference	Value	Quantity
C1	47u	1
C2, C3	100u	2
C4, C5, C11, C14	47n	4
C6	6n8	1
C7	47p	1
C8, C17	10u	2
C9, C13, C16	10n	3
C10	100p	1
C12, C15	1u	2
C20	1u5	1
C21	68n	1
C22	8n2	1
C23	39n	1
C24	1n2	1
C25	22n	1
D1	1N5817	1
D2, D3, D4, D5, D6	1N4148	5
D102		1
Dist, Level	A50k	2
High, Low	B10k	2
IC1, IC2	M5218	2
I01		1
I02		1
I03		1
I04		1
I05		1
Q1	2SK209-GR	1
Q3, Q4, Q5, Q6	2N5088	4
R1	CLR	1
R2, R15	2k2	2
R3, R4, R5, R7, R12, R16, R27, R30, R33	10k	9
R6, R18, R34	1M	3
R8	4k7	1
R9	47k	1
R10, R11	220	2
R13	220k	1
R14	22k	1
R17	5k6	1
R19, R20	3k3	2
R25, R28, R31	100k	3
R26, R32	330	2

Reference	Value	Quantity
R29	1k	1

Copyright: Sheepllove.com 2026-03-04

ResDef

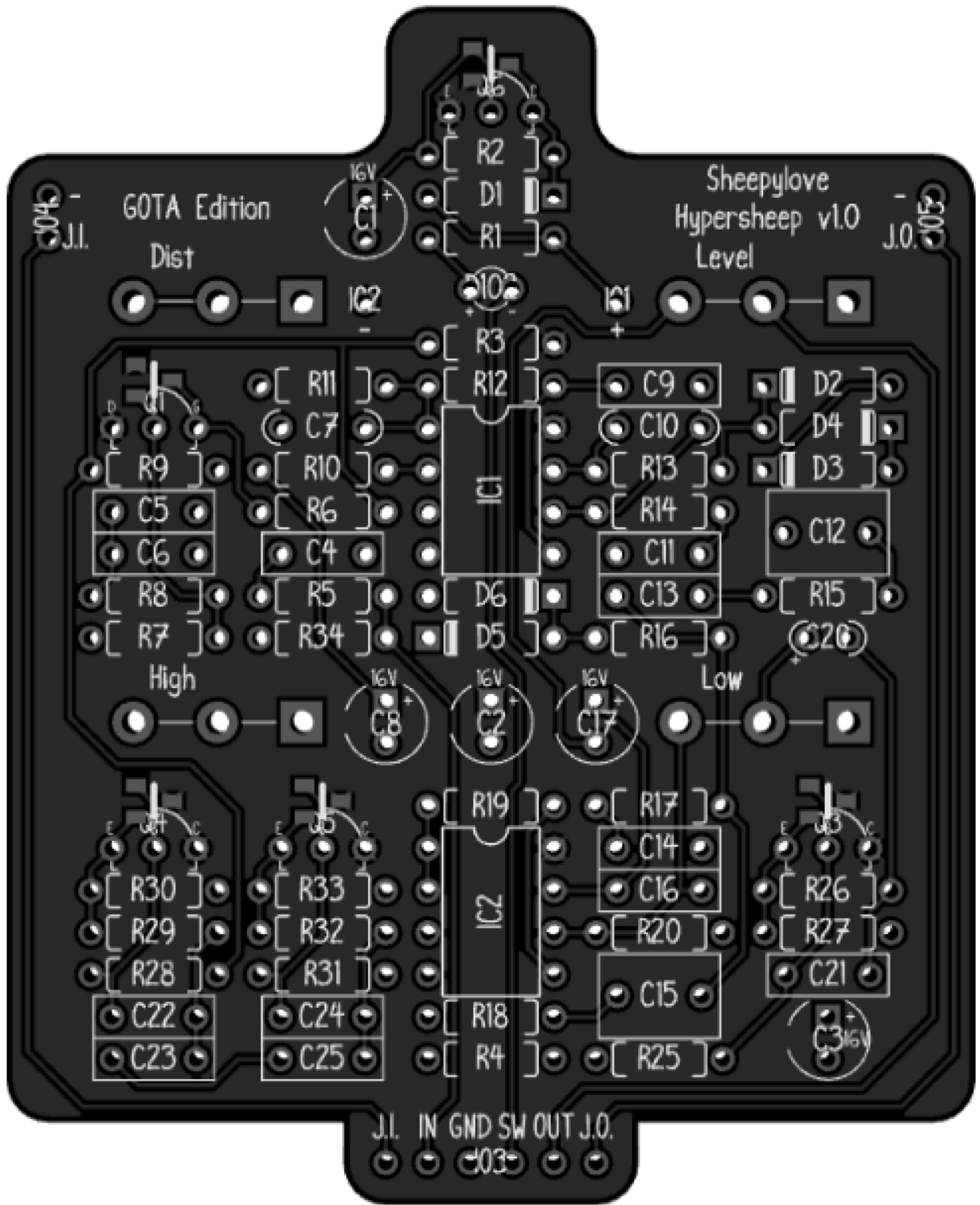

Copyright: Sheepylove.com 2026-03-04

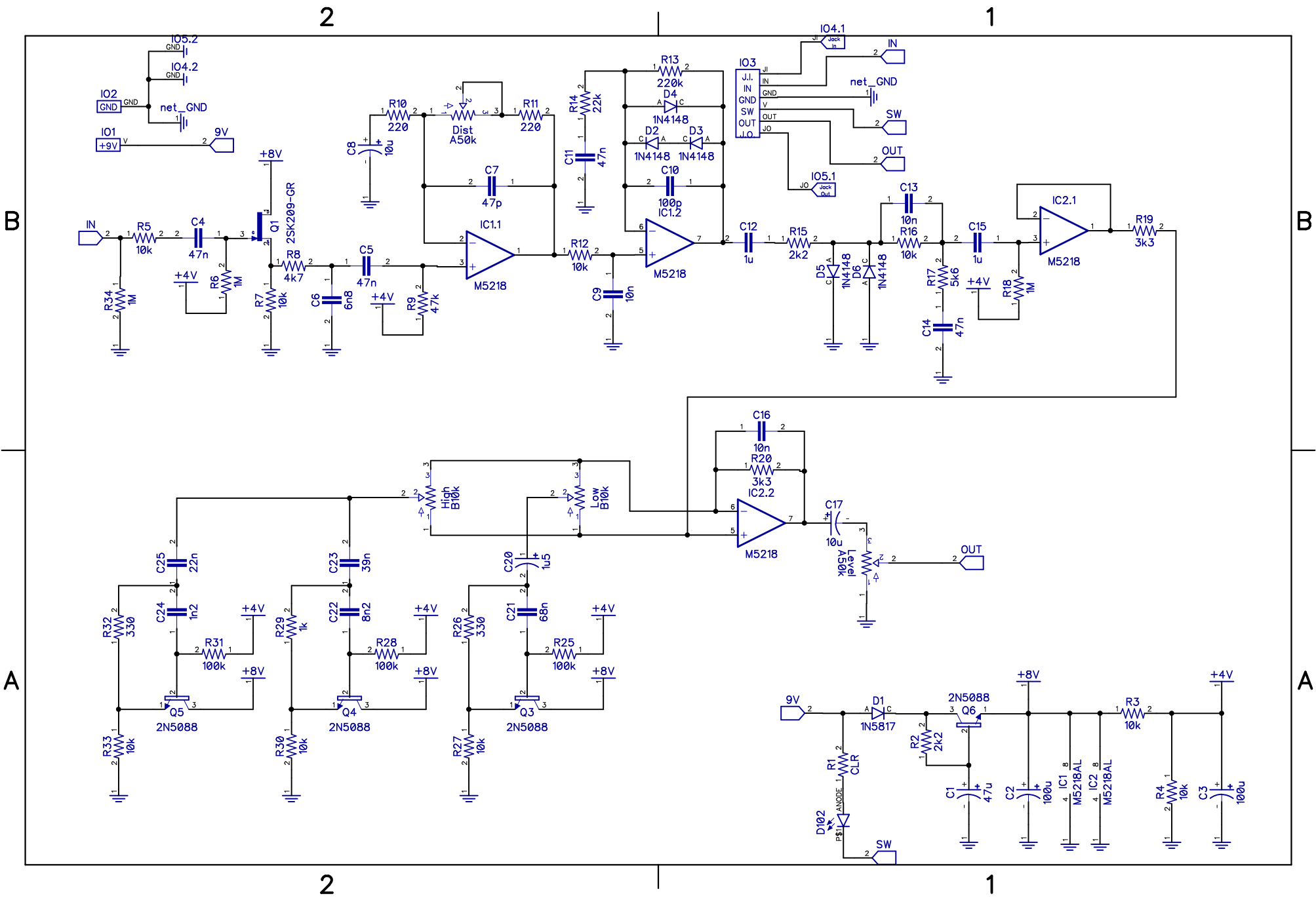

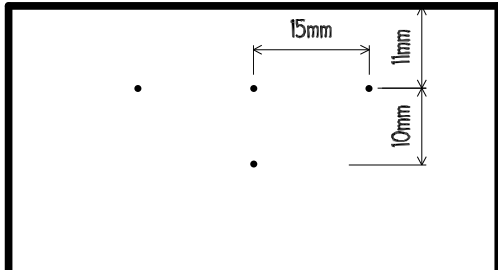

Sheepylove Drill Template

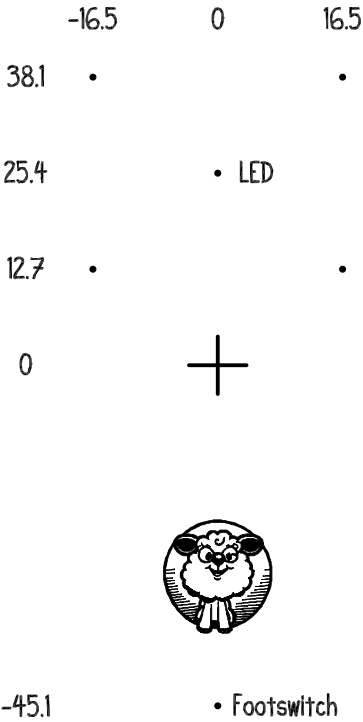

All units are in millimeters.