

Sheepylove Thunder Gun Express Build Doc

Updated: 2026-03-02

It's woolly, it's greasy, it's Sheepylove.

Disclaimer: All trademarks and registered trademarks are the property of their respective owners. The company, product, and service names used in this document are for comparative purposes only. Use of these names, logos, and brands does not imply affiliation nor endorsement.

Sounds like Apocalypse Audio Thundertone with mods by Chuck D Bones

A lower gain Supro drive.

Copyright: Sheepylove.com 2026-03-02

Bill of Materials

Reference	Value	Quantity	Notes
C1	100u	1	
C2	4n7	1	
C3	2u2	1	
C4	1n	1	
C5,C9	47n	2	
C6	3n3	1	
C7,C12	10n	2	
C8	22u	1	
C10	560p	1	
C11	470n	1	
D1	1N5817	1	
D2	LED	1	
POT1	A50k	1	
POT2	B500k	1	
POT5	A100k	1	
POT6	B50k	1	
Q1,Q2	MMBF4393	2	
Q3	Ge NPN	1	
R1	CLR	1	
R2	100	1	
R3	3M3	1	
R4,R20	22k	2	
R5	270k	1	
R6,R13,RV1,RV2	10k	4	
R7	560	1	
R8	39k	1	
R9	1k	1	
R10	150k	1	
R11,R18	100k	2	
R12	330	1	
R14	27k	1	
R15	3k9	1	
R16	6k8	1	
R17	560k	1	
R19	470	1	

Copyright: Sheepllove.com 2026-03-02

PCB Images

Top View

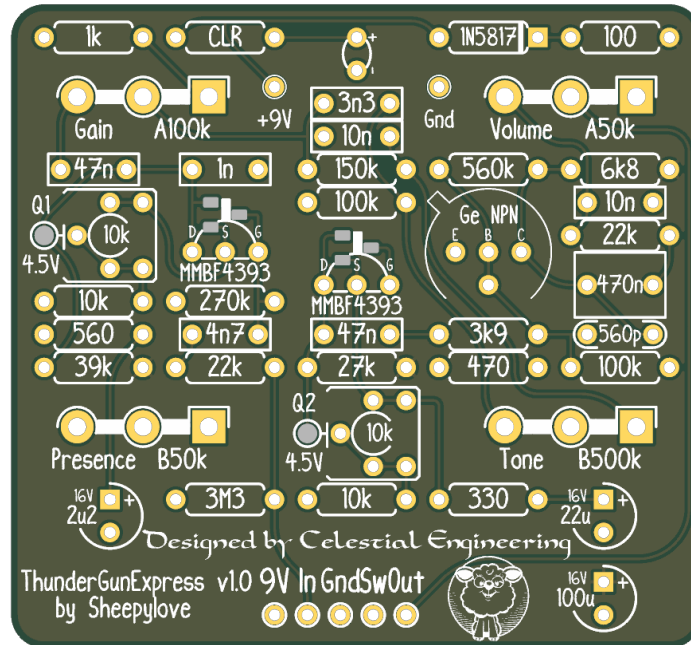

Bottom View

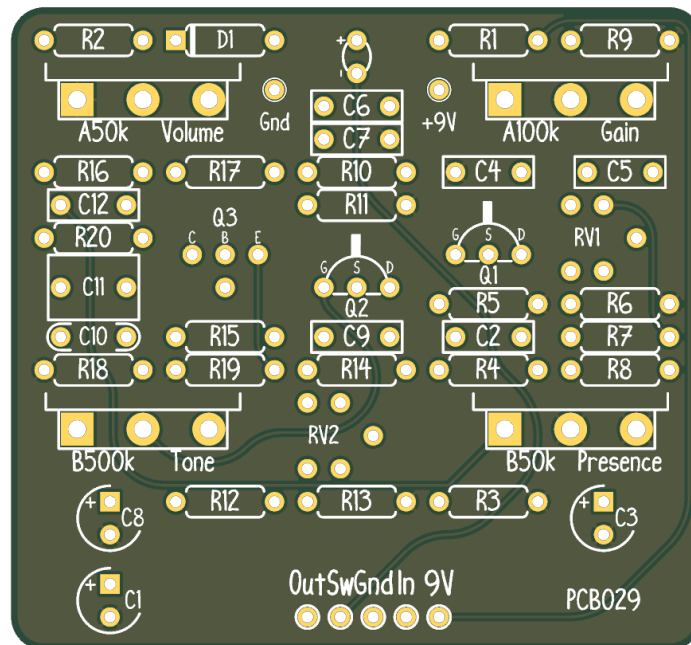

Copyright: Sheepllove.com 2026-03-02

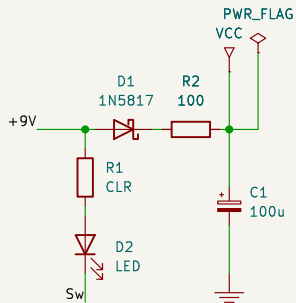
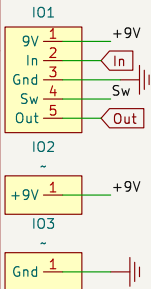
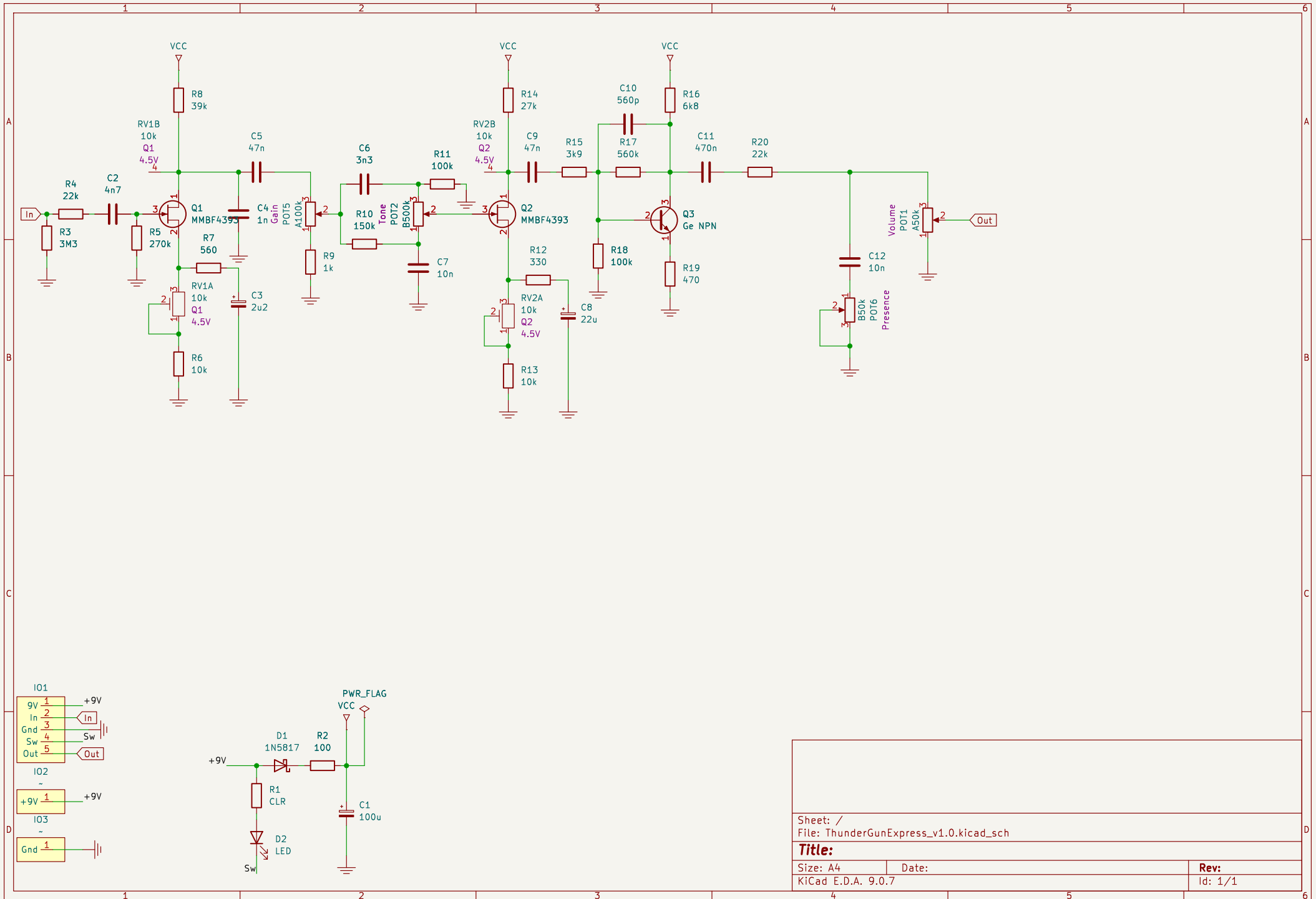

Sheet: /
 File: ThunderGunExpress_v1.0.kicad_sch

Title:

Size: A4
 KiCad E.D.A. 9.0.7

Date:

Rev:
 Id: 1/1

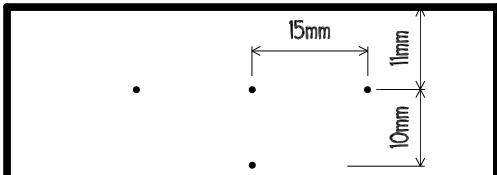

With a sheepy kind of love.

Sheepylove Drill Template

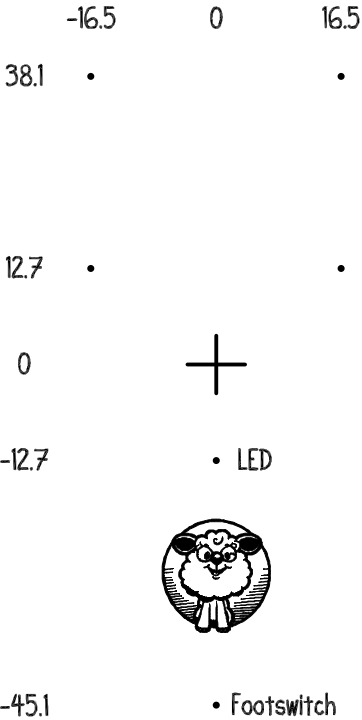

Print 1:1 scale.
All units are in millimeters.