

# Sheepylove BogFuzz Build Doc

Updated: 2026-05-08

It's woolly, it's greasy, it's Sheepylove.

**Disclaimer:** All trademarks and registered trademarks are the property of their respective owners. The company, product, and service names used in this document are for comparative purposes only. Use of these names, logos, and brands does not imply affiliation nor endorsement.

**Sounds like Dunlop JHF-3 with mods by Celestial Engineering**

Copyright: Sheepylove.com 2026-05-08

## Bill of Materials

Reference	Value	Quantity	Notes
C1	100u	1	
C2	10n	1	
C3	2n2	1	
C4	1n	1	
C5,C10	22u	2	
C6	47p	1	
C7,C13	4n7	2	
C8	10u	1	
C9	100n	1	
C11	220p	1	
C12	1u	1	
C14	6n8	1	
D1	1N5817	1	
D2	LED	1	
POT1	A100k	1	
POT2	C1k	1	
POT3	C50k	1	
Q1	BC560C	1	
Q2	BC549C	1	
Q3	MP38A	1	
R1	CLR	1	
R2	2M2	1	
R3	820k	1	
R4	680k	1	
R5	180k	1	
R6	220k	1	
R7	560	1	
R8	100	1	
R9,R13,R14	1k	3	
R10	47k	1	
R11	22k	1	
R12	470	1	
SW1	0n/0ff/0n	1	

Copyright: Sheepllove.com 2026-05-08



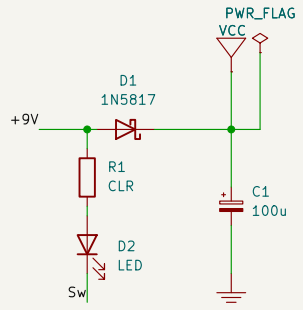
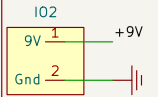
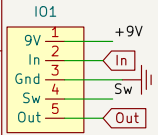
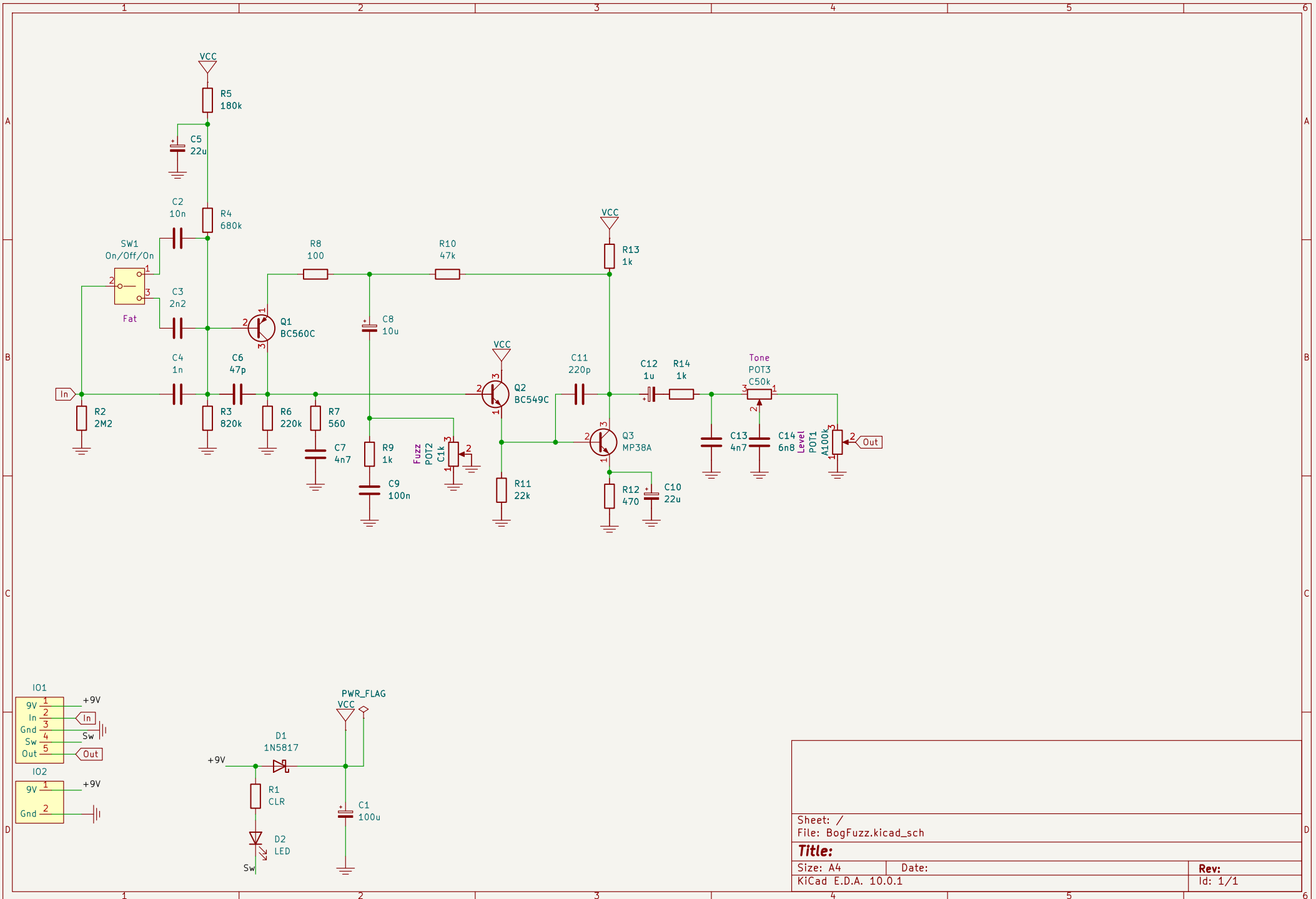

Sheet: /	
File: BogFuzz.kicad_sch	
<b>Title:</b>	
Size: A4	Date:
KiCad E.D.A. 10.0.1	Rev: 1/1

