

Sheepylove Speedy Sheep Build Doc

Updated: 2026-02-24

It's woolly, it's greasy, it's Sheepylove.

Disclaimer: All trademarks and registered trademarks are the property of their respective owners. The company, product, and service names used in this document are for comparative purposes only. Use of these names, logos, and brands does not imply affiliation nor endorsement.

Sounds like Greer Lightspeed

Take a Greer Lightspeed, which is taken from a Timmy, and add a switch to get more gain from it.

At the speed of sheep!

Copyright: Sheepylove.com 2026-02-24

Bill of Materials

Reference	Value	Quantity	Notes
C1,C2	22u	2	
C3,C5	47n	2	
C4	100p	1	
C6,C11	220n	2	
C7	470n	1	
C8,C10	1u	2	
C9	10n	1	
D1	1N5817	1	
D2	LED	1	
D3-D7	1N914	5	
IC1	OPA2134	1	
POT1	A100k	1	
POT2	A500k	1	
POT4	A10k	1	
R1	CLR	1	
R2	1M	1	
R3,R12	4k7	2	
R4,R6,R10,R11	5k6	4	
R5	430k	1	
R7,R14	3k3	2	
R8	1k5	1	
R9	12k	1	
R13	3k9	1	
SW1	0n/0n	1	

Copyright: Sheepllove.com 2026-02-24

PCB Images

Top View

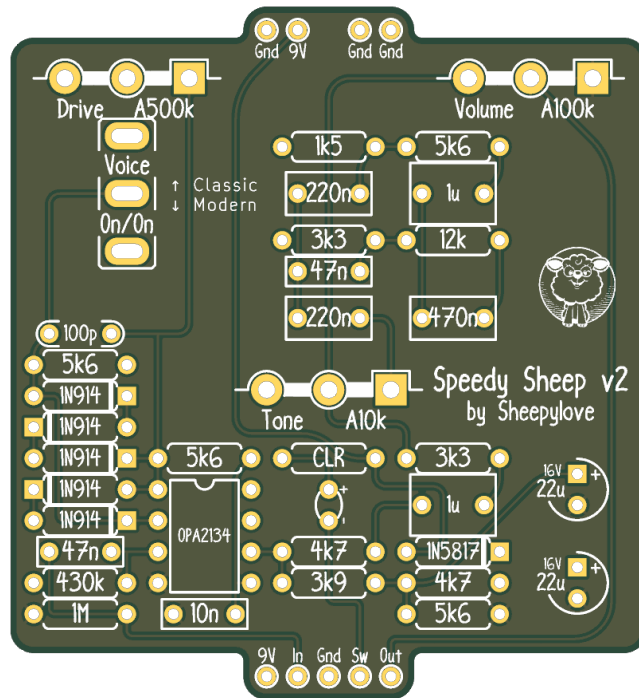

Bottom View

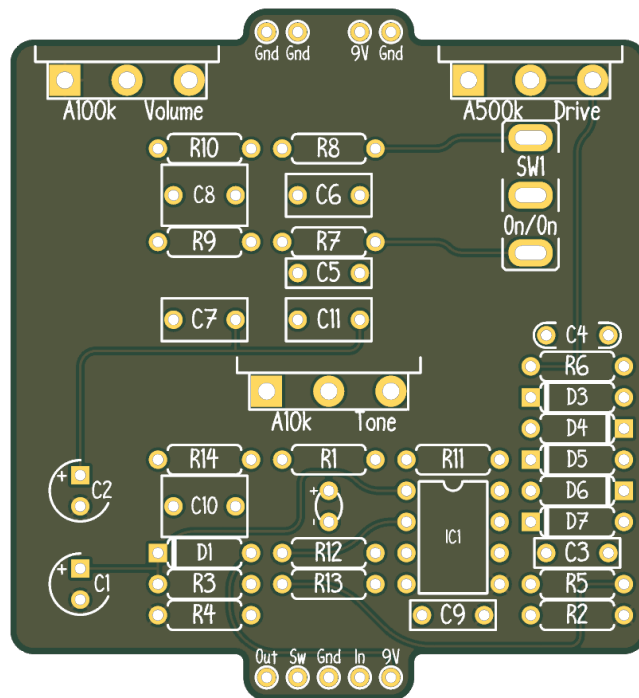

Copyright: Sheepllove.com 2026-02-24

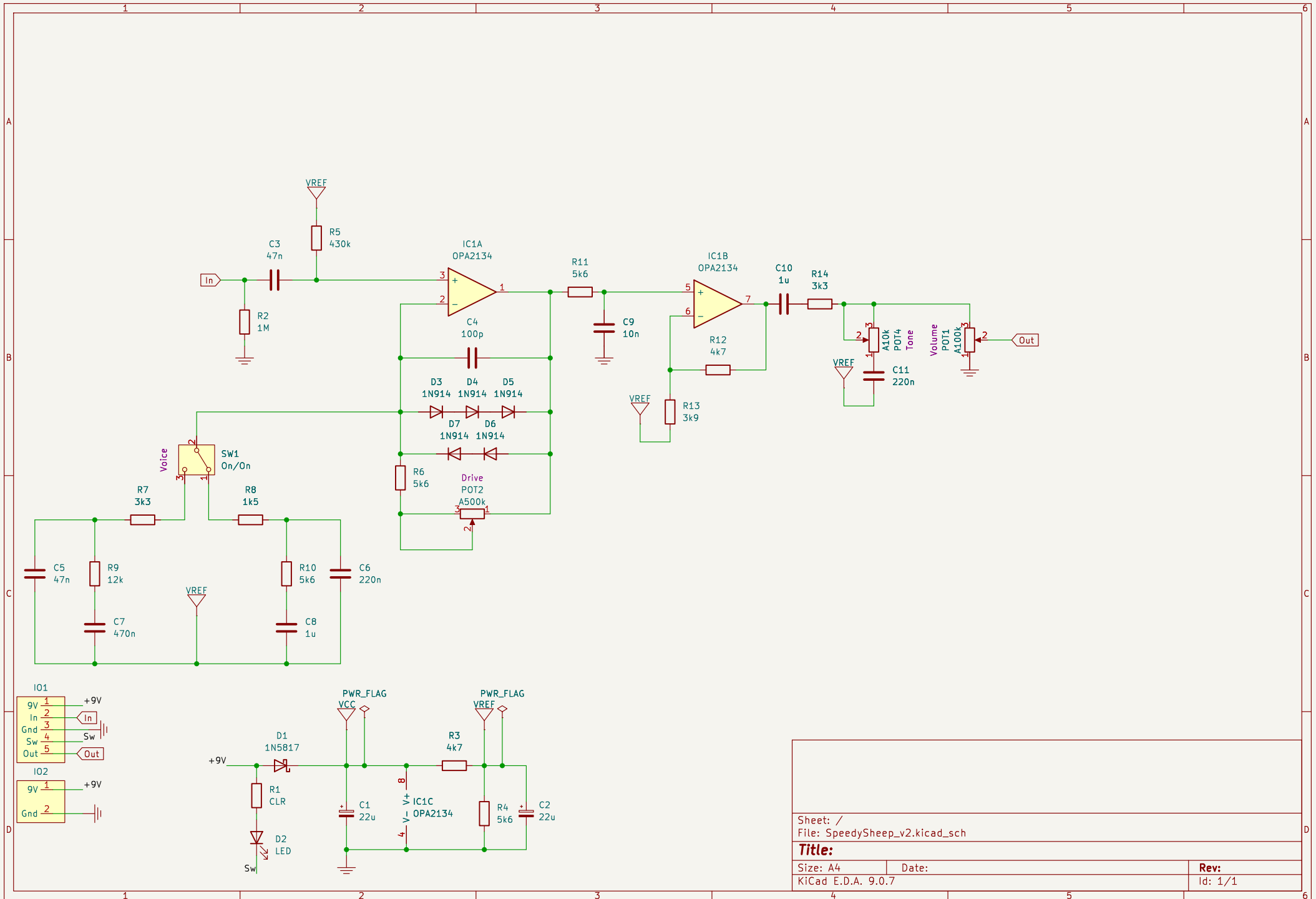

Sheet: /	
File: SpeedySheep_v2.kicad_sch	
Title:	
Size: A4	Date:
KiCad E.D.A. 9.0.7	Rev:
	Id: 1/1

