

Sheepylove Sacrificial Lamb Build Doc

Updated: 2026-02-22

It's woolly, it's greasy, it's Sheepylove.

Disclaimer: All trademarks and registered trademarks are the property of their respective owners. The company, product, and service names used in this document are for comparative purposes only. Use of these names, logos, and brands does not imply affiliation nor endorsement.

Sounds like Basic Audio Alter Destiny

It's a Big Muff with an added Mid and Fat (bass) control. Gives good options to dial that intense low end that you know and love.

Copyright: Sheepylove.com 2026-02-22

Bill of Materials

Reference	Value	Quantity	Notes
C1	100u	1	
C2,C4,C7,C10,C17,C18	100n	6	
C3,C8,C11	560p	3	
C5	2n2	1	
C6	4n7	1	
C9,C12	47n	2	
C15,C16	10n	2	
D1	1N5817	1	
D2	LED	1	
D3,D4	1N914	2	
D5,D6	BAT42	2	
I02,I05	~	2	
P0T1,P0T3,P0T5	B100k	3	
P0T4	B25k	1	
P0T6	B250k	1	
Q1-Q4	2N5088	4	BC549C is good, mind the pinout.
R1	CLR	1	
R2	100	1	
R3	1M	1	
R4,R19	3k3	2	
R5,R11,R16,R22	390k	4	
R6,R13,R15	82k	3	
R7,R12,R18	820	3	
R8	2k2	1	
R9,R14	8k2	2	
R10,R21	100k	2	
R17,R25	22k	2	
R20	39k	1	
R23	2k7	1	
R24	12k	1	

Copyright: Sheepllove.com 2026-02-22

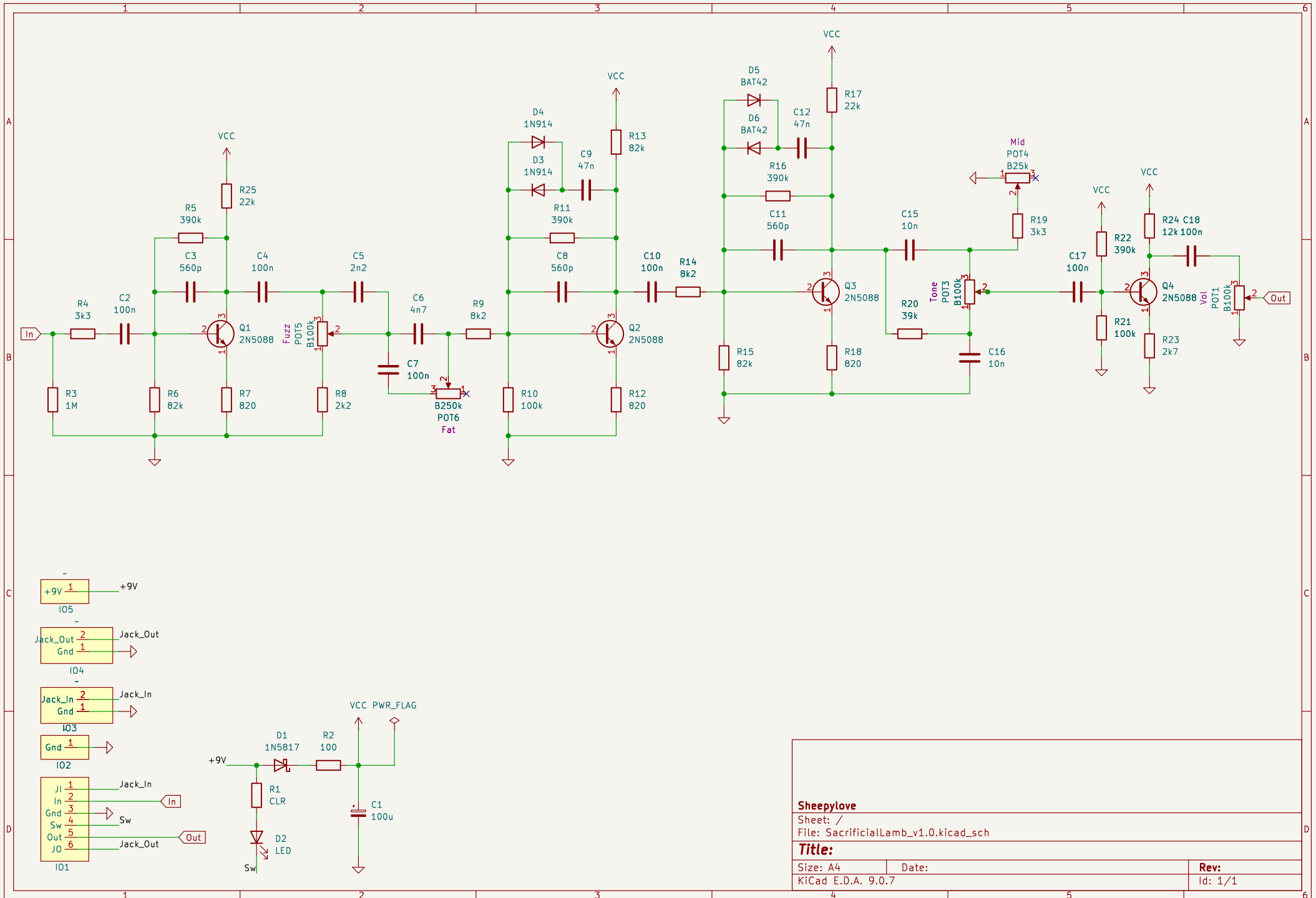

Sheepllove	
Sheet: /	
File: SacrificialLamb_v1.0.kicad_sch	
Title:	
Size: A4	Date:
KiCad E.D.A. 9.0.7	Rev: 1/1

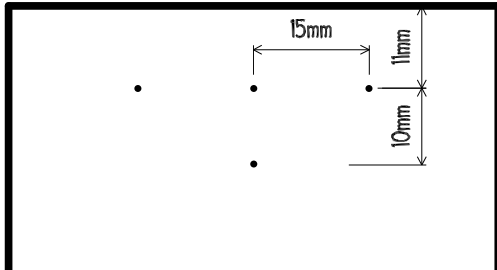

Sheepylove Drill Template

-20.3 0 20.3

38.1 • • •

12.7 • • •
LED

0 +

-12.7



-45.1 • Footswitch

All units are in millimeters.