

# Sheepylove Wise Ass Build Doc

Updated: 2026-02-22

It's woolly, it's greasy, it's Sheepylove.

△ **LEGACY BUILD WARNING:** This is a legacy build. The I/O may be different from the standard and the LED may not be onboard or may not be in the place where you expect.

**Disclaimer:** All trademarks and registered trademarks are the property of their respective owners. The company, product, and service names used in this document are for comparative purposes only. Use of these names, logos, and brands does not imply affiliation nor endorsement.

## Sounds like a Vivie Minerva

Based on the Blues Breaker with a gyrator added.

Copyright: Sheepylove.com 2026-02-22

## Bill of Materials

Reference	Value	Quantity
C1	100u	1
C2, C3, C7, C8, C21	100n	5
C4	10u	1
C5	3n3	1
C6, C9	1n	2
C10, C16, C20	10n	3
C11	82n	1
C12, C15, C18	4n7	3
C13	1n5	1
C14	47n	1
C17	2n2	1
C19	8n2	1
C22	1u	1
D1	1N5817	1
D2, D3	1N914	2
GAIN, LEVEL	B100K	2
IC1, IC2	TL072	2
IC3	NE5532	1
R1, R2, R24, R26, R27	10K	5
R3	1M	1
R4, R8, R13	470K	3
R5	22K	1
R6	680R	1
R7, R14	15K	2
R9, R12	6K8	2
R10	5K1	1
R11, R17	2K2	2
R15	8K2	1
R16, R23	4K7	2
R18	220K	1
R19, R21, R29	1K	3
R20, R28	100K	2
R22	150K	1
R25	100R	1
SW_1	ON/ON	1
TONE, TUBE	B10K	2
U1		1
U2		1



ResDef

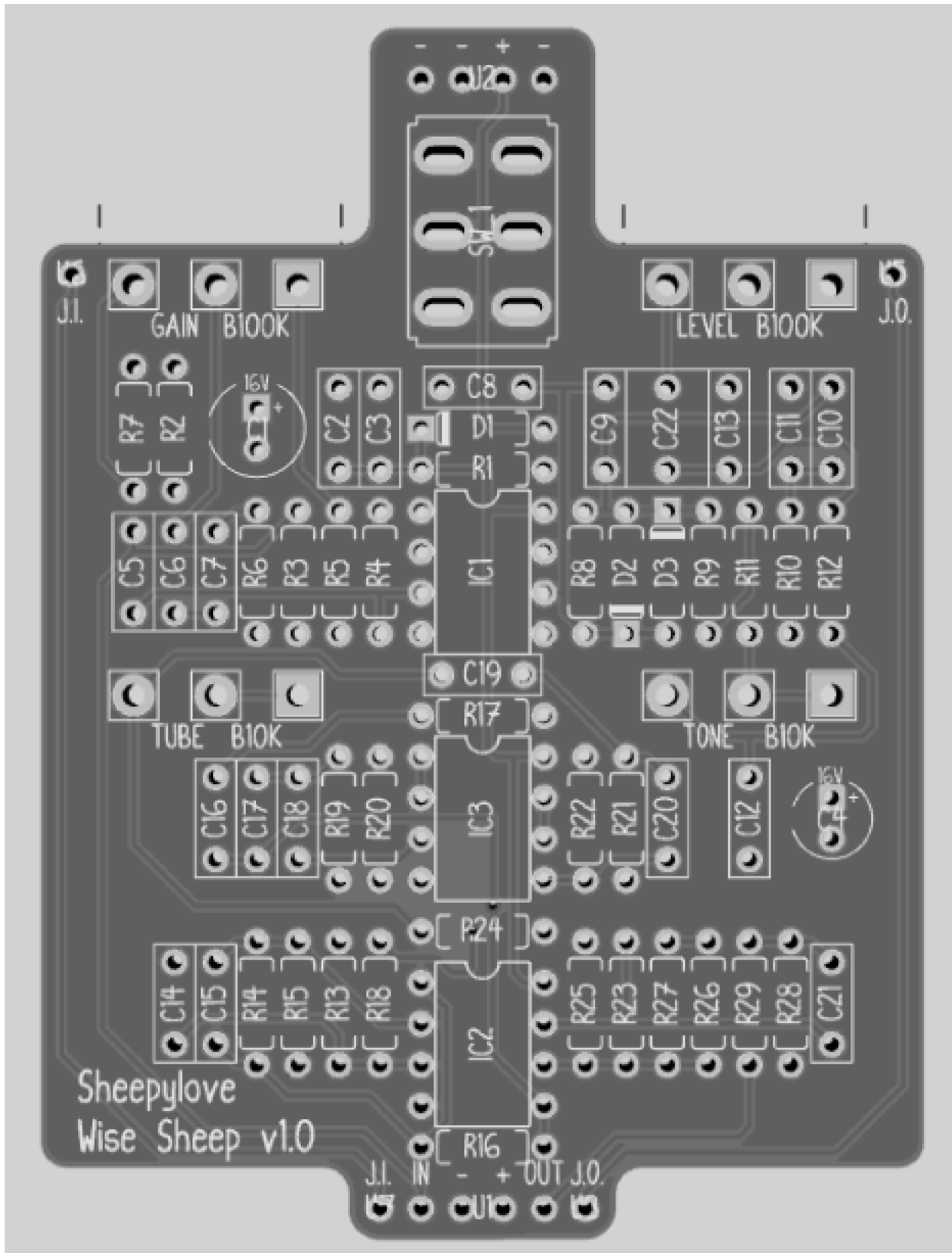

Copyright: Sheepllove.com 2026-02-22

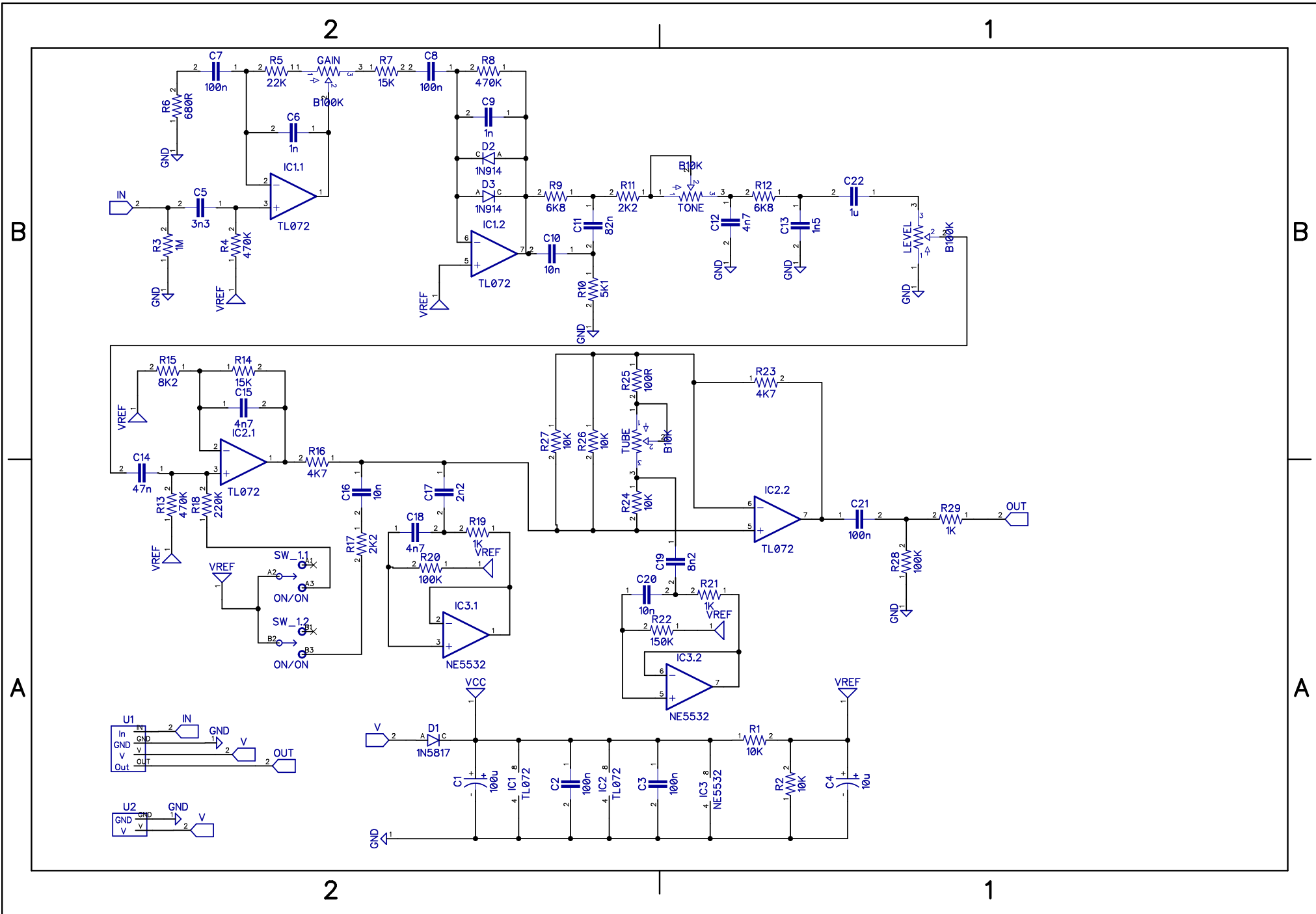

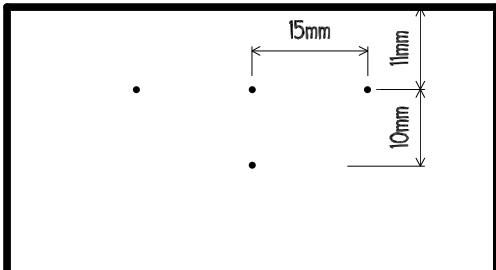

### Sheepylove Drill Template

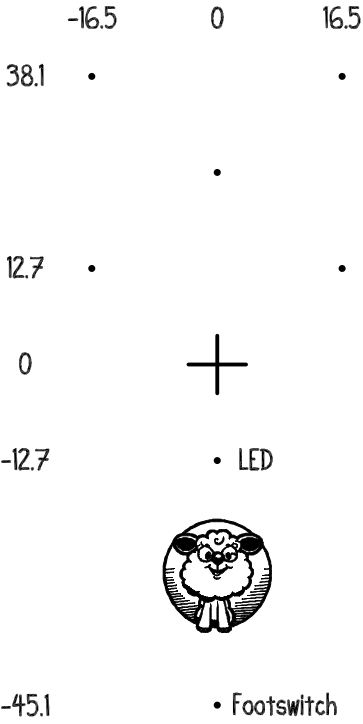

Print 1:1 scale.  
All units are in millimeters.