

Sheepylove Gold Sheep Build Doc

Updated: 2026-02-21

It's woolly, it's greasy, it's Sheepylove.

Disclaimer: All trademarks and registered trademarks are the property of their respective owners. The company, product, and service names used in this document are for comparative purposes only. Use of these names, logos, and brands does not imply affiliation nor endorsement.

Sounds like Klon Centaur

Another classic, you've heard it everywhere, it kicks hard in the mids.

If you care about diodes, find your precious Ge, else just chuck some BATs in there and be happy in the mix.

Copyright: Sheepylove.com 2026-02-21

Bill of Materials

Reference	Value	Quantity	Notes
C1,C2	47u	2	
C3-C6,C12-C14	1u	7	
C7,C8	100n	2	
C9,C17	68n	2	
C10	82n	1	
C11	390p	1	
C15	2n2	1	
C16	27n	1	
C18	390n	1	
C19	820p	1	
C20	3n9	1	
C21	4u7	1	
D1	1N4742	1	
D2	LED	1	
D3,D4	1N4001	2	
D5,D6	Ge/BAT41	2	BATs are fine, mojo is wine.
IC1,IC3	TL072	2	
IC2	ICL7660S	1	
POT1,POT4	B10k	2	
POT2	B100k Dual	1	
R1	CLR	1	
R2,R3,R20	27k	3	
R4,R6	2M	2	
R5,R7	10k	2	
R8	2k	1	
R9,R12	15k	2	
R10	422k	1	
R11,R18	1k5	2	
R13,R19	1k	2	
R14	47k	1	
R15	22k	1	
R16	12k	1	
R17	5k1	1	
R21	392k	1	
R22	1k8	1	
R23,R24	100k	2	
R25	4k7	1	
R26	560	1	

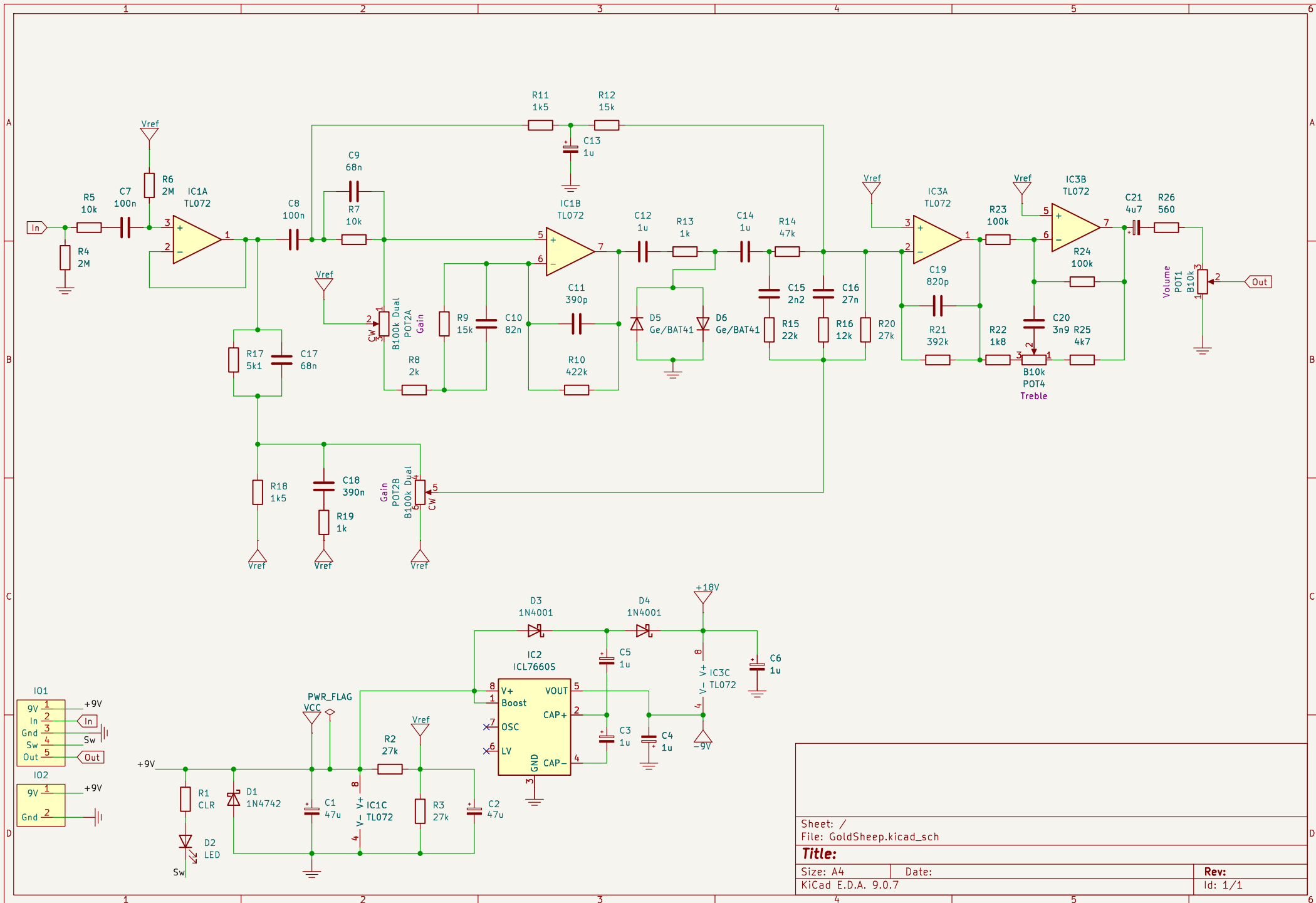

Sheet: /	
File: GoldSheep.kicad_sch	
Title:	
Size: A4	Date:
KiCad E.D.A. 9.0.7	Rev:
	Id: 1/1

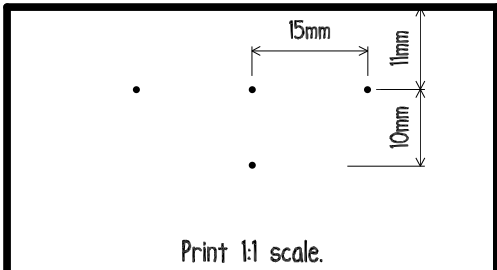

Sheepylove Drill Template

-16.5	0	16.5
38.1	•	•
12.7	•	
0	+	
-12.7	• LED	
		
-45.1	• Footswitch	

Print 1:1 scale.
All units are in millimeters.